



FUJI
ELECTRIC

SPLIT TYPE
AIR CONDITIONER

CASSETTE type (50Hz)

SERVICE MANUAL

Models	Indoor unit	Outdoor unit
	RCW-12	RO-12CA
	RCW-12R	RO-12HA
	RCW-14	RO-14CA
	RCW-14R	RO-14HA
	RCW-18A	RO-18CA
	RCW-18RA	RO-18HA

C O N T E N T S

SPECIFICATIONS	1
OUTLINE AND DIMENTIONS	2
CIRCUIT DIAGRAM	4
REFRIGERANT SYSTEM DIAGRAM	7
ERROR CONTENTS	9
P. C. BOARD DIAGRAM	10
DISASSEMBLY ILLUSTRATION	12
PARTS LIST	21
STANDARD ACCESSORIES	23



Большая библиотека технической документации

<https://splitsystema48.ru/instrukcii-po-ekspluatacii-kondicionerov.html>

каталоги, инструкции, сервисные мануалы, схемы.

S P E C I F I C A T I O N S

TYPE		COOL	COOL & HEAT	COOL	COOL & HEAT	COOL	COOL & HEAT	
MODEL	IN	RCW-12	RCW-12R	RCW-14	RCW-14R	RCW-18A	RCW-18RA	
	OUT	RO-12CA	RO-12HA	RO-14CA	RO-14HA	RO-18CA	RO-18HA	
COOLING CAPACITY		kW	3.65 - 3.70	3.60 - 3.65	4.00 - 4.10	3.90 - 4.00	4.95 - 5.10	4.85 - 5.00
HEATING CAPACITY		kW	-----	4.00 - 4.10	-----	4.50 - 4.70	-----	5.30 - 5.45

ELECTRICAL SPECIFICATIONS

POWER SOURCE		220 - 240 V 50Hz						
RUNNING CURRENT	(A)	COOL	5.8 - 5.5	5.9 - 5.5	7.4 - 7.4	7.4 - 7.4	8.7 - 8.5	8.2 - 8.0
		HEAT	-----	5.8 - 5.5	-----	7.4 - 7.4	-----	8.9 - 8.5
INPUT WATTS	(kW)	COOL	1.27 - 1.30	1.27 - 1.30	1.55 - 1.60	1.55 - 1.60	1.90 - 2.00	1.80 - 1.90
		HEAT	-----	1.25 - 1.28	-----	1.55 - 1.65	-----	1.90 - 2.00
E.E.R.	(kW/kW)	COOL	2.87 - 2.85	2.83 - 2.81	2.58 - 2.56	2.52 - 2.50	2.61 - 2.55	2.69 - 2.63
		HEAT	-----	3.20 - 3.20	-----	2.90 - 2.85	-----	2.79 - 2.73
MOISTURE REMOVAL		ℓ / hr	1.6	1.6	1.8	1.8	2.1	2.1
AIR CIRCULATION - HI		(m ³ / hr)	550	550	550	550	650	650

COMPRESSOR

TYPE		Hermetic type					
CODE		QJ236PD24B		QJ282PC24A		2JS31ZD5BA02	
		220 - 240V 50Hz		220 - 240V 50Hz		220 - 240V 50Hz	
REFRIGERANT	R-22 (g)	950	950	1,000	950	1,450	1,600

FAN MOTOR

POWER SUPPLY		240					
INDOOR UNIT	TYPE	MFA-14GTT		MFA-14GTT		MFA-18GTT	
	HI-SPEED (r.p.m.)	750		750		820	
	MED-SPEED (r.p.m.)	670		670		740	
	LO-SPEED (r.p.m.)	590		590		620	
OUTDOOR UNIT	TYPE	MFB-14DTT		MFB-14DTT		MFB-252TAT	
	HI / LO (r.p.m.)	580 / 280		580 / 280		740 / 280	

DIMENSIONS

INDOOR UNIT	H x W x D (mm)	235 x 580 x 580 +70					
OUTDOOR UNIT		643 x 840 x 336					
GRILLE		35 x 650 x 650					

WEIGHT

INDOOR UNIT	NET / GROSS (kg)	18 / 23		18 / 23		18 / 23	
OUTDOOR UNIT		51 / 59	52 / 60	51 / 59	52 / 60	59 / 67	68 / 76
GRILLE		2.2 / 4.3		2.2 / 4.3		2.2 / 4.3	

REFRIGERANT CHARGE

MODELS	PIPE LENGTH	5 m (16 ft)	10 m (33 ft)	15 m (49 ft)	20 m (66 ft)	Additional refrigerant g/m (oz. / ft)
	FULL CHARGE AMOUNT	RCW-12	950g (33.5 oz.)	1,000g (35.3 oz.)	1,050g (37.0 oz.)	
RCW-12R		1,000g (35.3 oz.)	1,070g (37.9 oz.)	1,150g (40.6 oz.)	1,225g (43.2 oz.)	15 (0.53)
RCW-14		1,000g (35.3 oz.)	1,050g (37.0 oz.)	1,100g (38.8 oz.)	1,150g (40.6 oz.)	10 (0.35)
RCW-14R		1,000g (35.3 oz.)	1,075g (37.9 oz.)	1,150g (40.6 oz.)	1,225g (43.2 oz.)	15 (0.53)
RCW-18A		1,170g (41.3 oz.)	1,245g (43.9 oz.)	1,320g (46.6 oz.)	1,395g (49.2 oz.)	15 (0.53)
RCW-18RA		1,800g (63.5 oz.)	1,950g (68.8 oz.)	2,100g (74.1 oz.)	2,250g (79.4 oz.)	30 (1.06)

OUTLINE AND DIMENSIONS

INDOOR UNIT

Models : RCW-12
 RCW-12R
 RCW-14
 RCW-14R
 RCW-18A
 RCW-18RA

(Unit : mm)

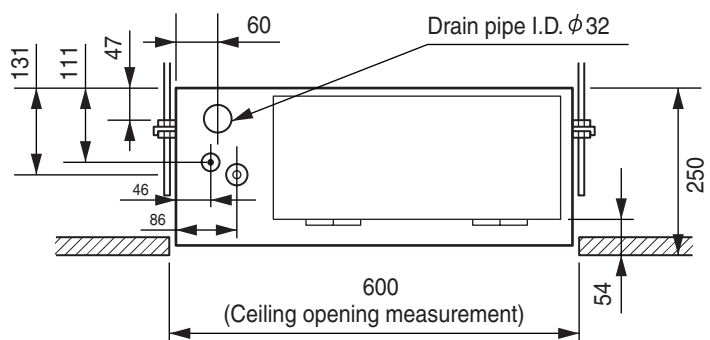
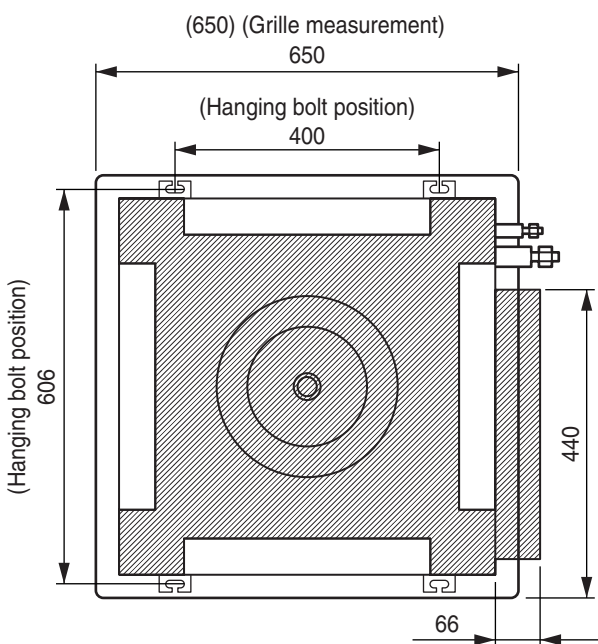
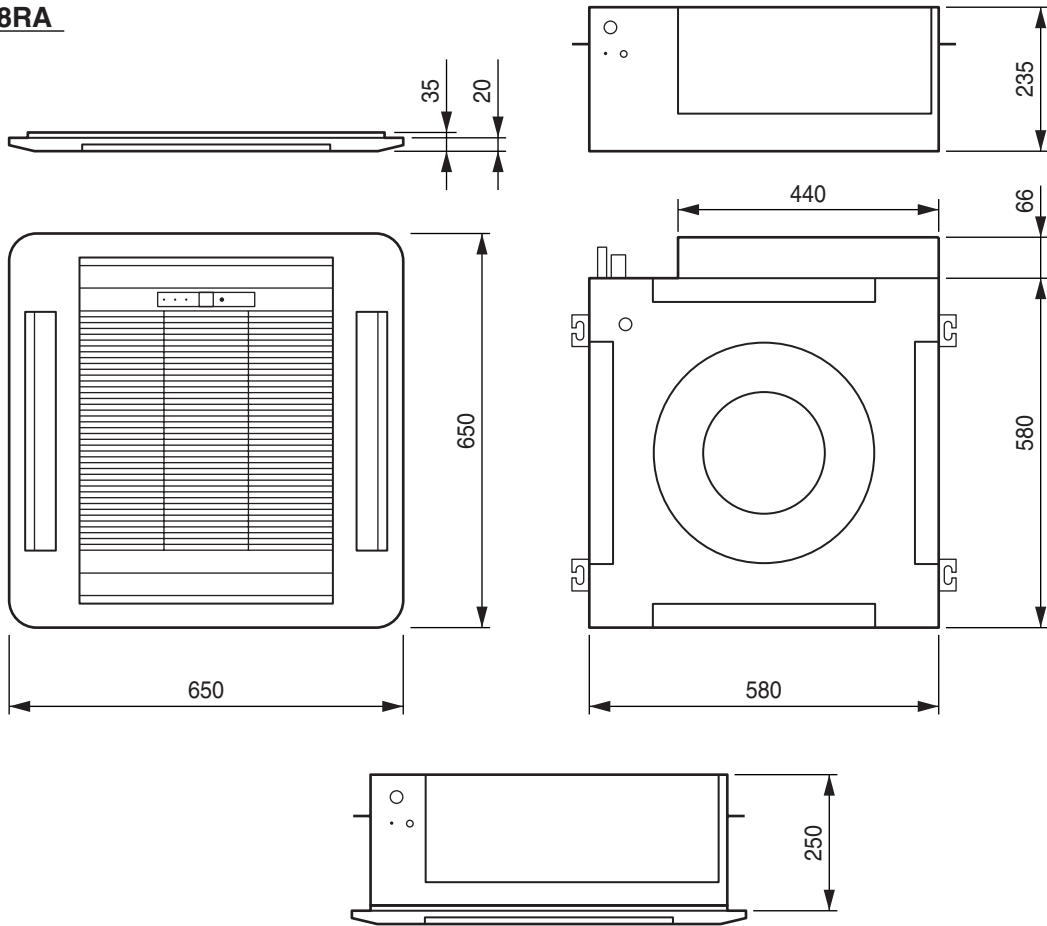

OUTDOOR UNIT

Models : RO-12CA
RO-12HA
RO-14CA
RO-14HA
RO-18CA
RO-18HA

(Unit : mm)

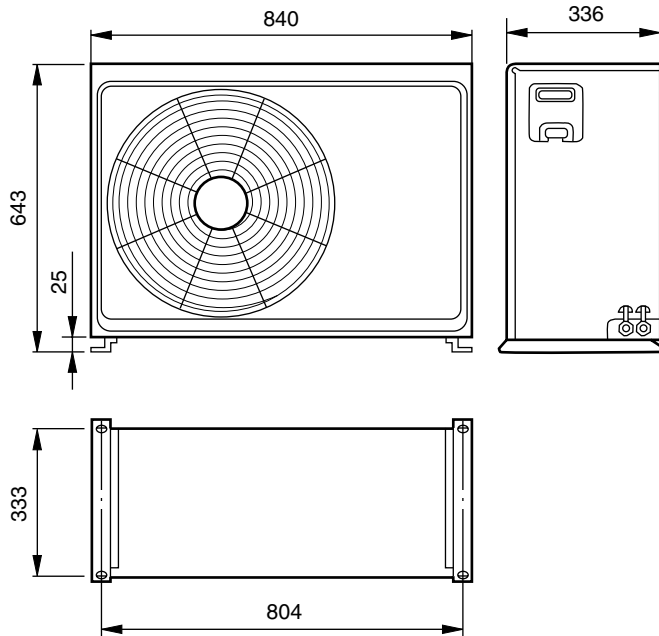

CIRCUIT DIAGRAM

Models : RCW-12
RCW-14
RCW-18A

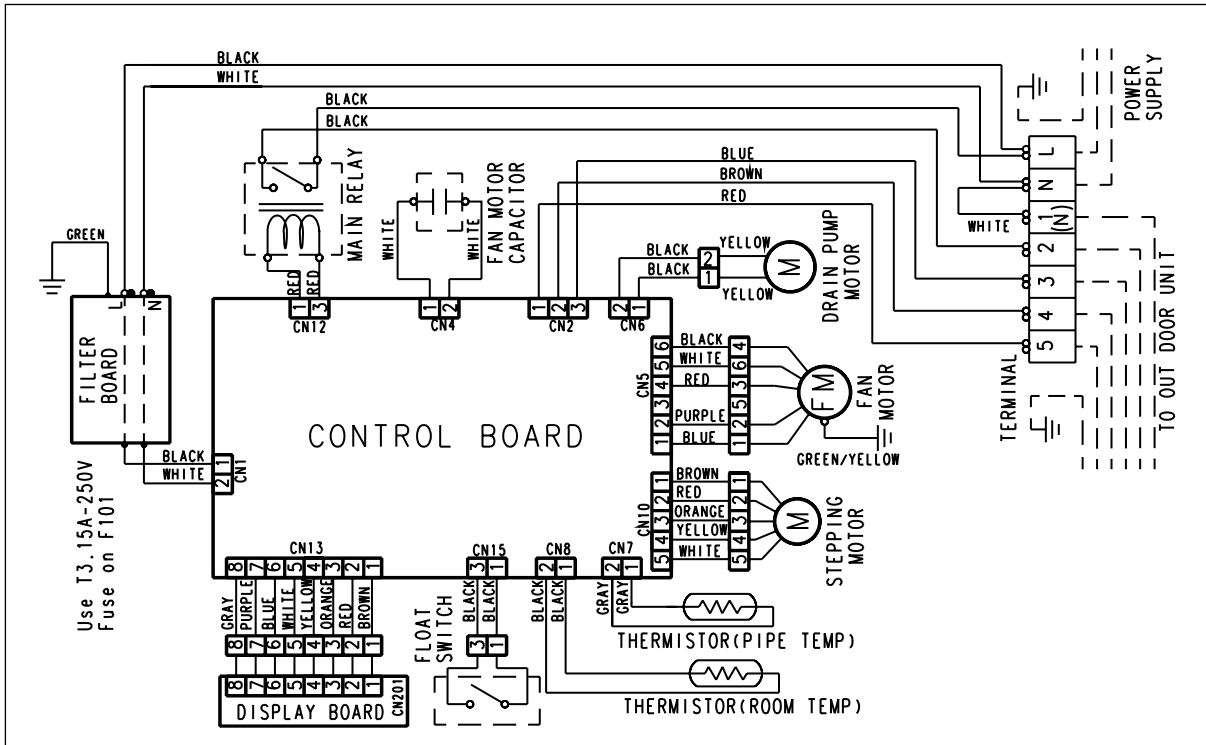

Models : RCW-12R
RCW-14R
RCW-18RA

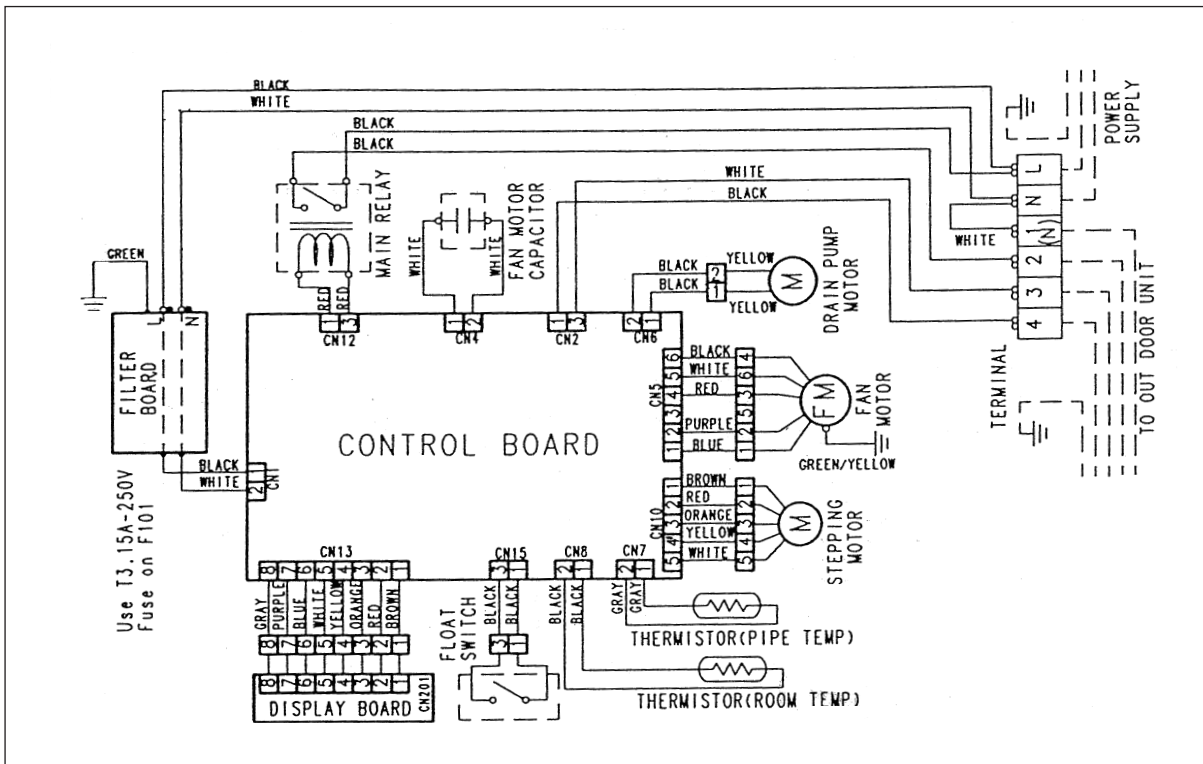

Model : RO-12CA

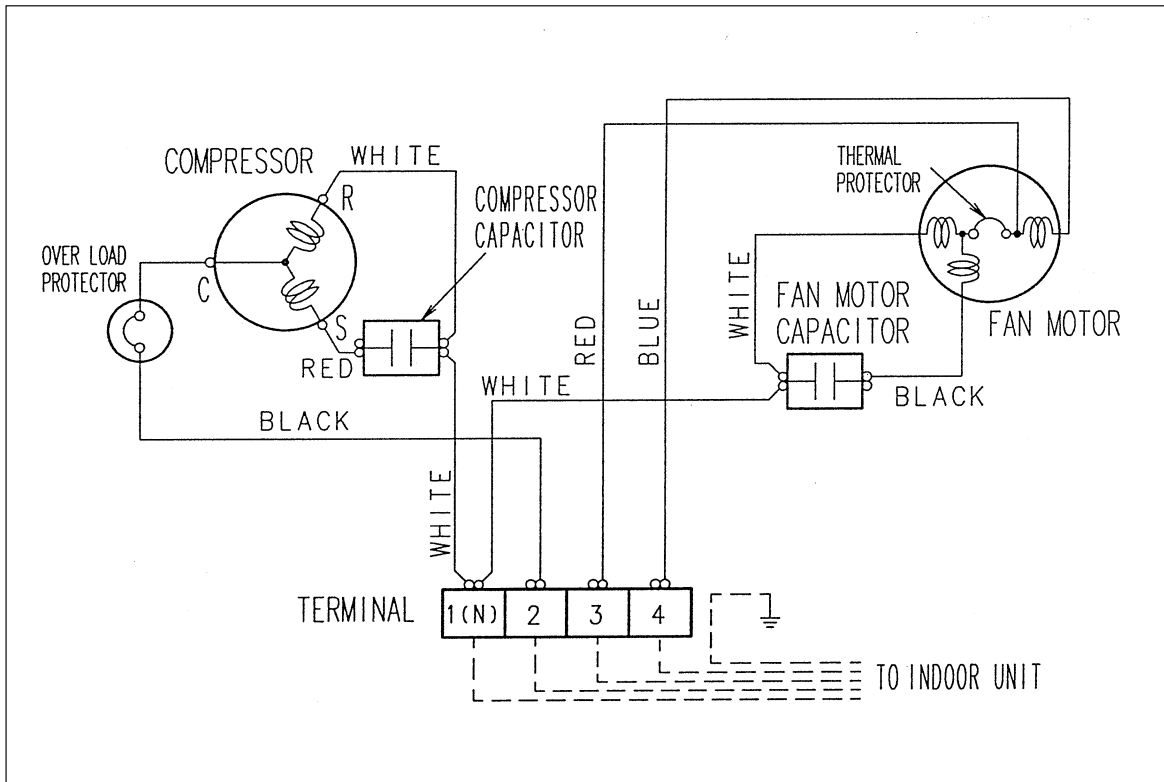

Model : RO-12HA

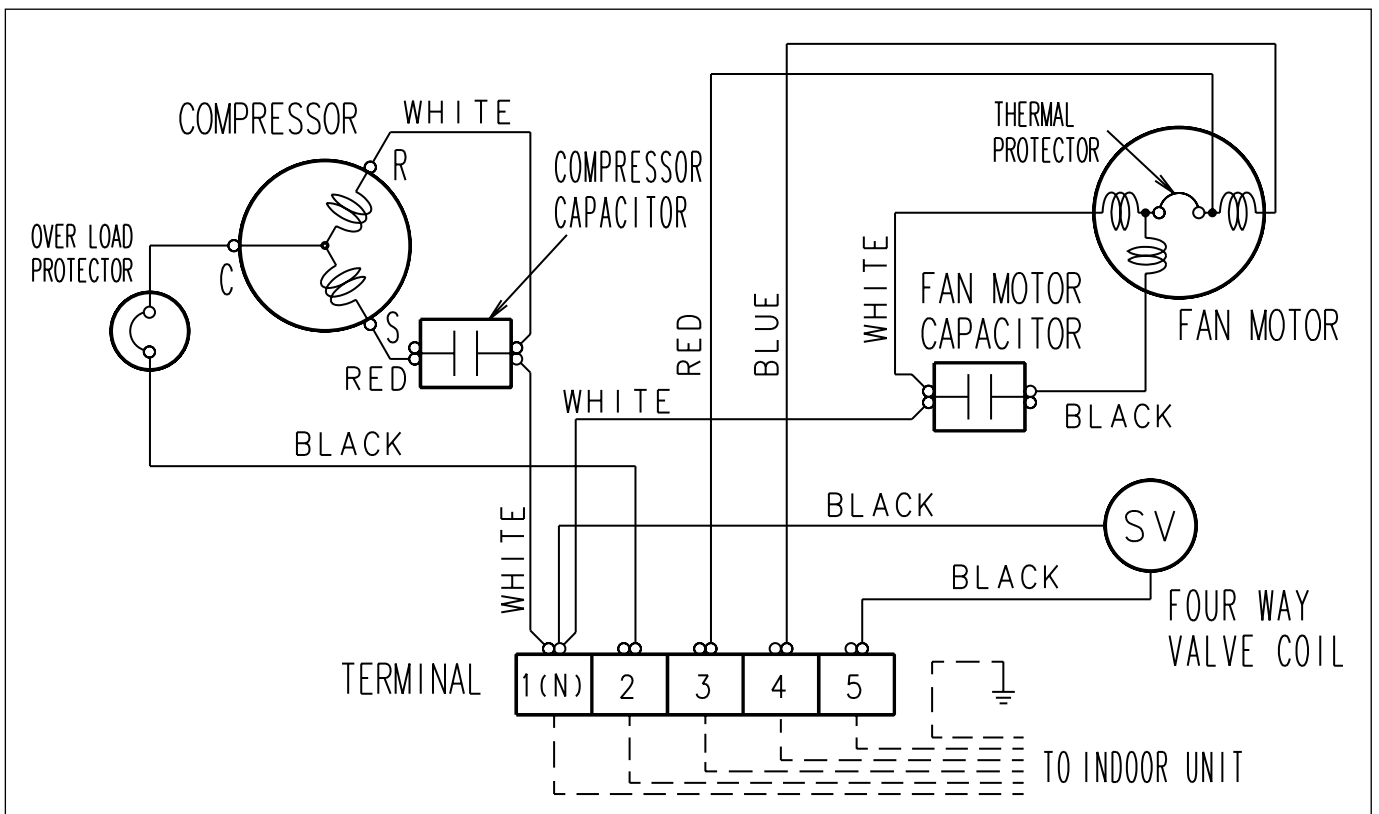

Models : RO-14CA
RO-18CA

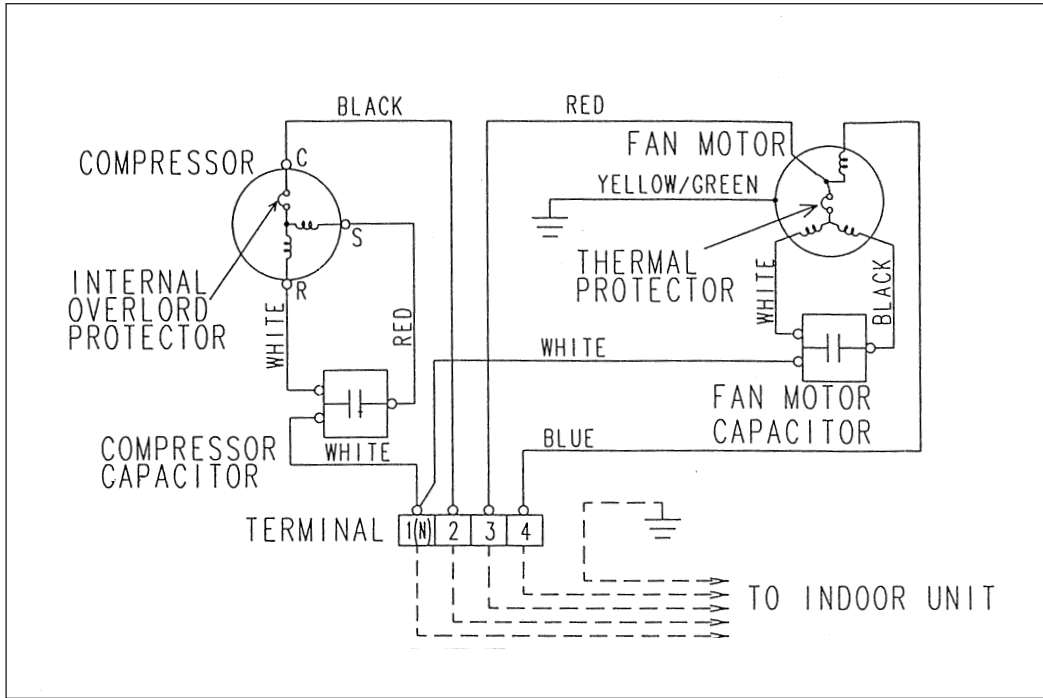

Models : RO-14HA
RO-18HA

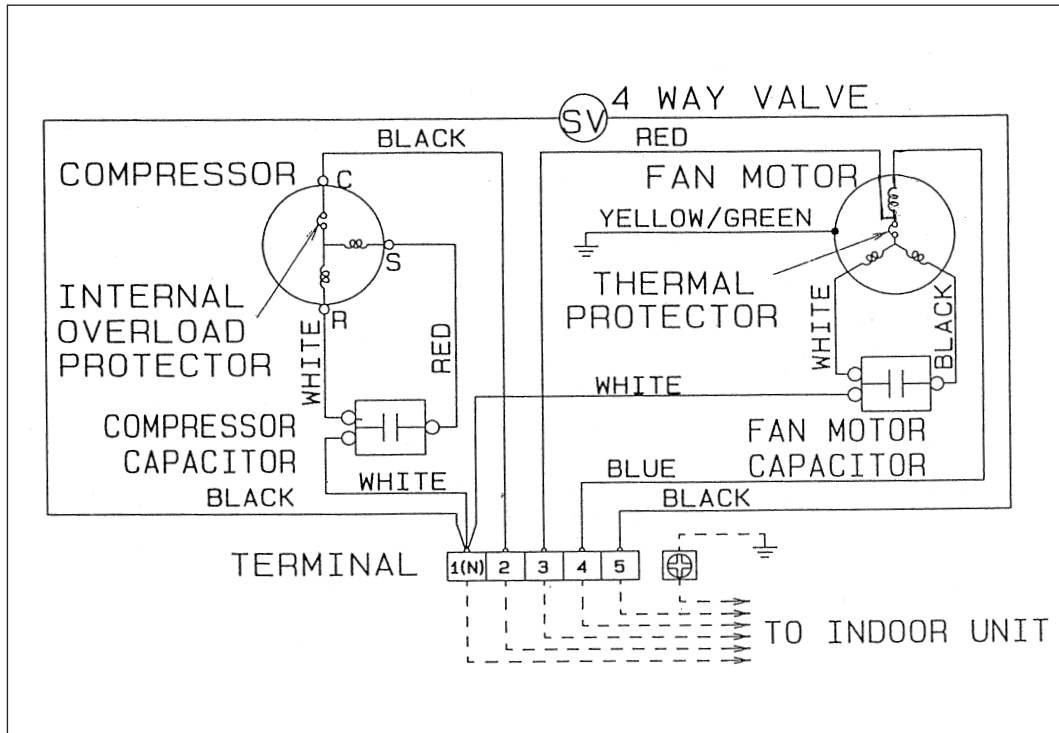

REFRIGERANT SYSTEM DIAGRAM

Models : RCW-12 / RO-12CA
 RCW-14 / RO-14CA
 RCW-18A / RO-18CA

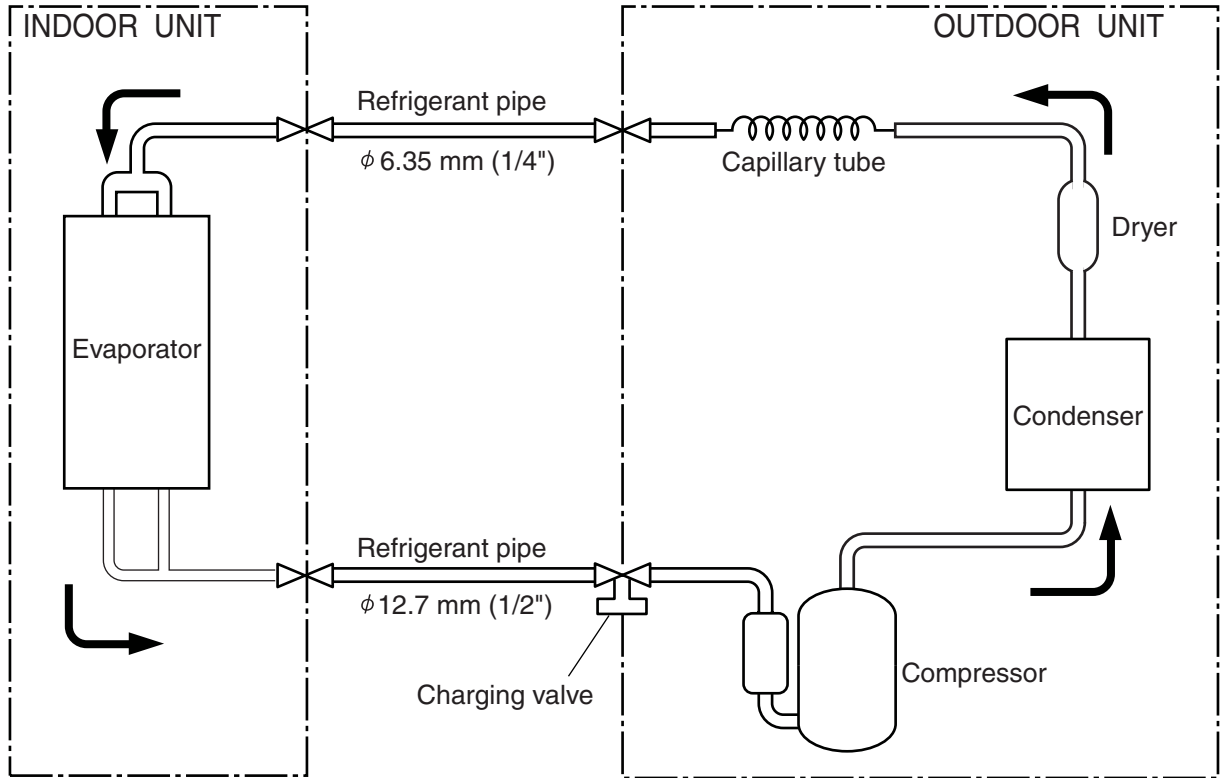

Models : RCW-12R / RO-12HA
 RCW-14R / RO-14HA

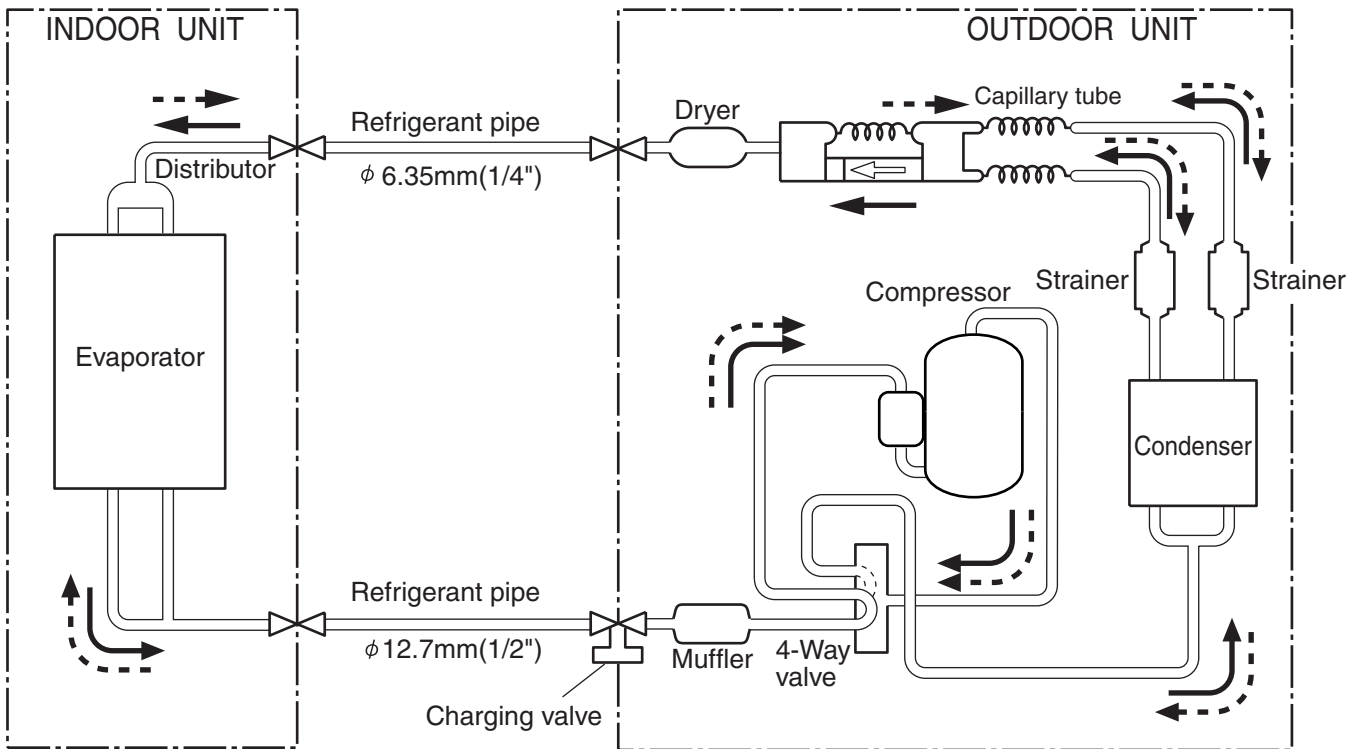

- Cooling
- Heating
- : Flare coupling

Models : RCW-18RA / RO-18HA

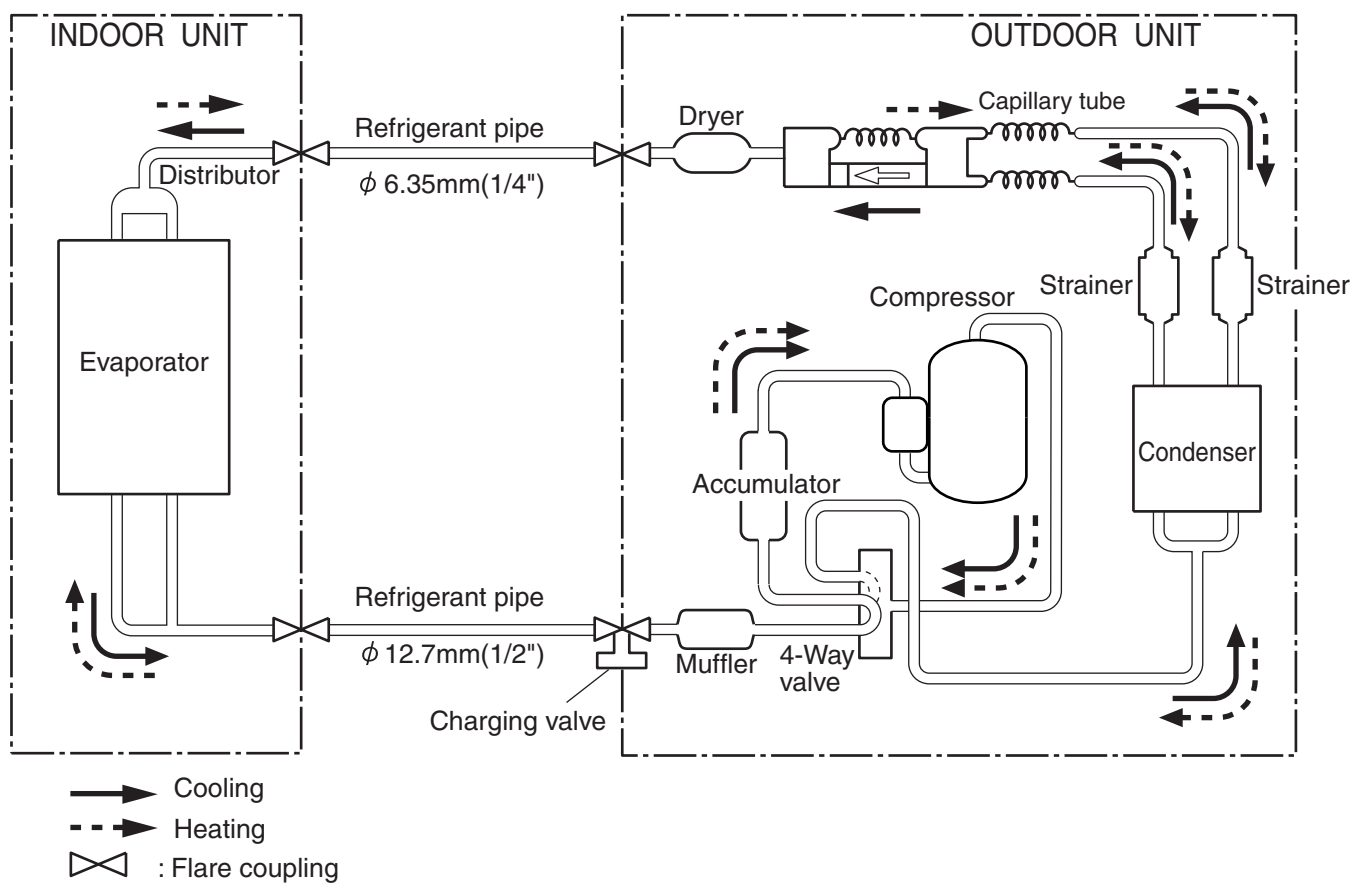

ERROR CONTENTS

TEST RUNNING

- Press the remote control unit test run button while the air conditioner is running.
- At the end of test running, press the remote control unit START/STOP button (Fig. 39).

Fig. 39

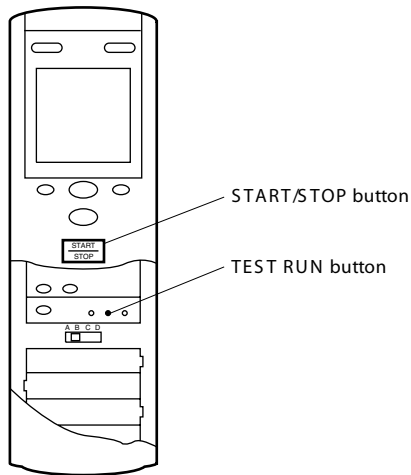

- Run the air conditioner in accordance with the operating manual.

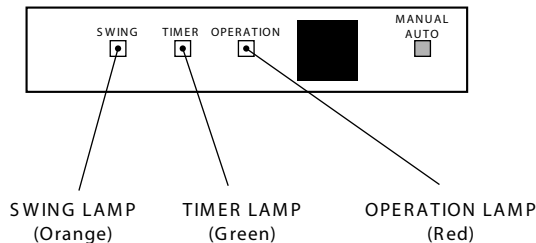

Operation can be checked by lighting and flashing of the grille display section OPERATION and TIMER lamps. Perform judgment in accordance with the following.

- Test running

When the air conditioner is run by pressing the remote control unit test run button, the OPERATION and TIMER lamps flash slowly at the same time.

- Error

The OPERATION and TIMER lamps operate as follows (Table 1) according to the error contents.

Table 1

Error display	Error contents
<p>OPERATION LAMP: Two quick flashes repeated (ON 0.5 sec, OFF 5 sec)</p> <p>TIMER LAMP: 0.1 sec ON/OFF repeated (ON 0.1 sec, OFF 0.1 sec)</p>	Room temperature thermistor abnormal temperature detected
<p>OPERATION LAMP: Three quick flashes repeated (ON 0.5 sec, OFF 5 sec)</p> <p>TIMER LAMP: 0.1 sec ON/OFF repeated (ON 0.1 sec, OFF 0.1 sec)</p>	Piping thermistor abnormal temperature detected
<p>OPERATION LAMP: Four quick flashes repeated (ON 0.5 sec, OFF 5 sec)</p> <p>TIMER LAMP: 0.1 sec ON/OFF repeated (ON 0.1 sec, OFF 0.1 sec)</p>	Float switch ON for 3 minutes or longer

CHECK ITEMS

(1) INDOOR UNIT

- (1) Is operation of each button on the remote control unit normal?
- (2) Does each lamp light normally?
- (3) Do not air flow direction louvers operate normally?
- (4) Is the drain normal?
- (5) Is there any abnormal noise and vibration during operation?

(2) OUTDOOR UNIT

- (1) Is there any abnormal noise and vibration during operation?
 - (2) Will noise, wind or drain water from the unit disturb the neighbors?
 - (3) Is there any gas leakage?
- Do not operate the air conditioner in the test running state for a long time.
 - For the operation method, refer to the operating manual and perform operation check.

INDOOR PRINTED CIRCUIT BOARD CIRCUIT DIAGRAM

Models : RCW-12
RCW-14
RCW-18A

CONTROLLER PCB ASSEMBLY (MAIN PCB) EZ-097EWSE-C

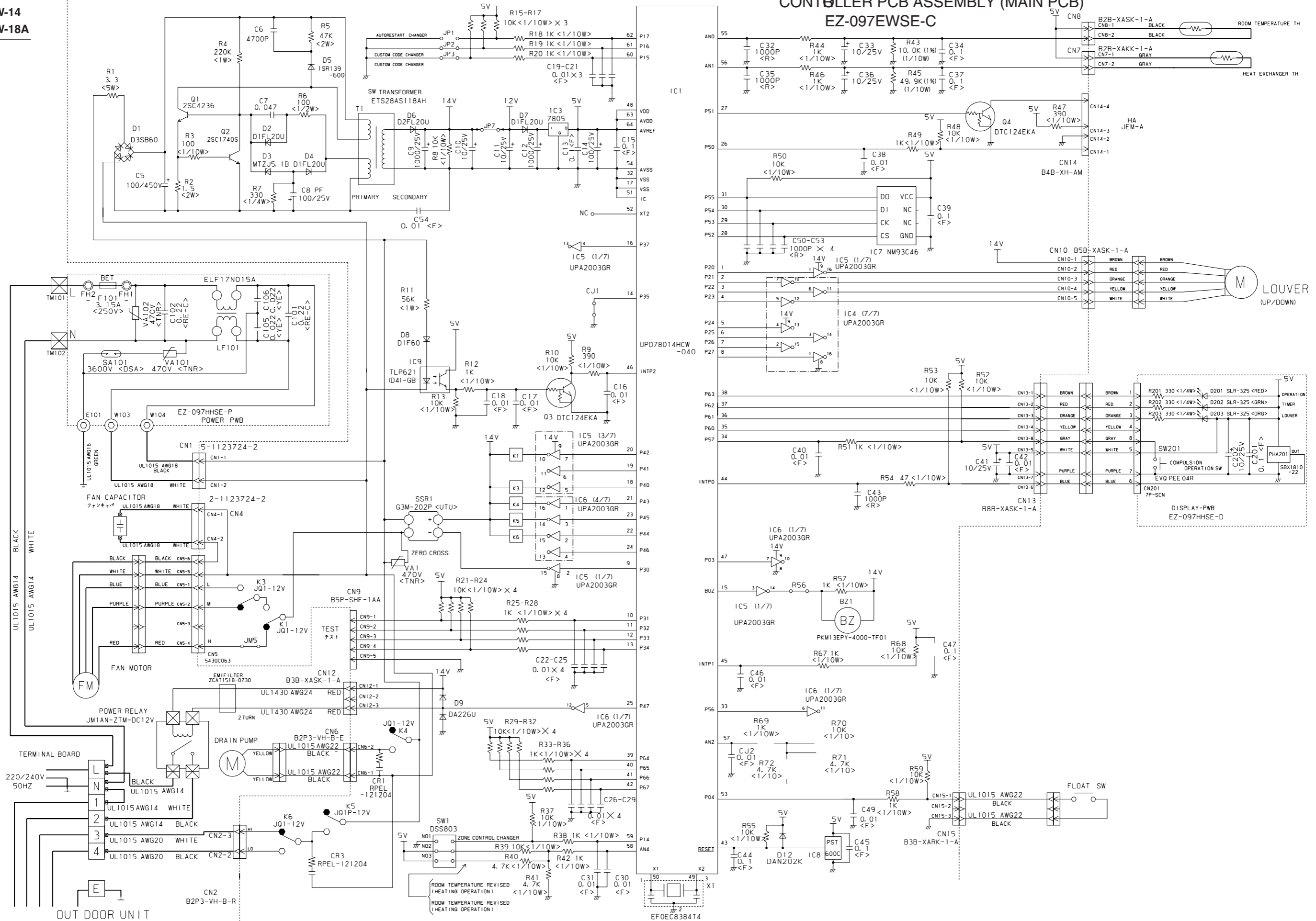

Models : RCW-12R
RCW-14R
RCW-18RA

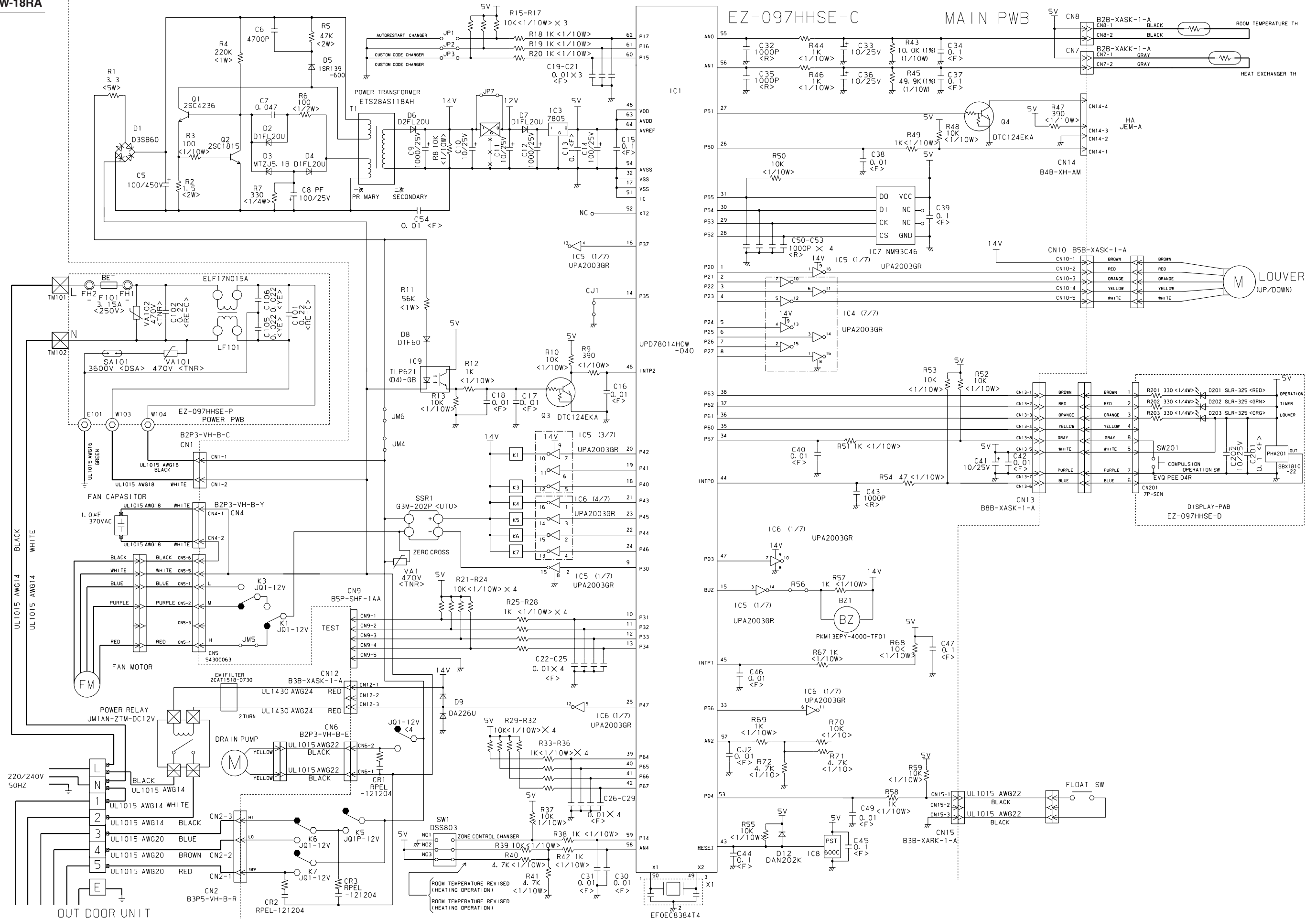

DISASSEMBLY ILLUSTRATION

Models : RCW-12
RCW-12R
RCW-14
RCW-14R
RCW-18A
RCW-18RA

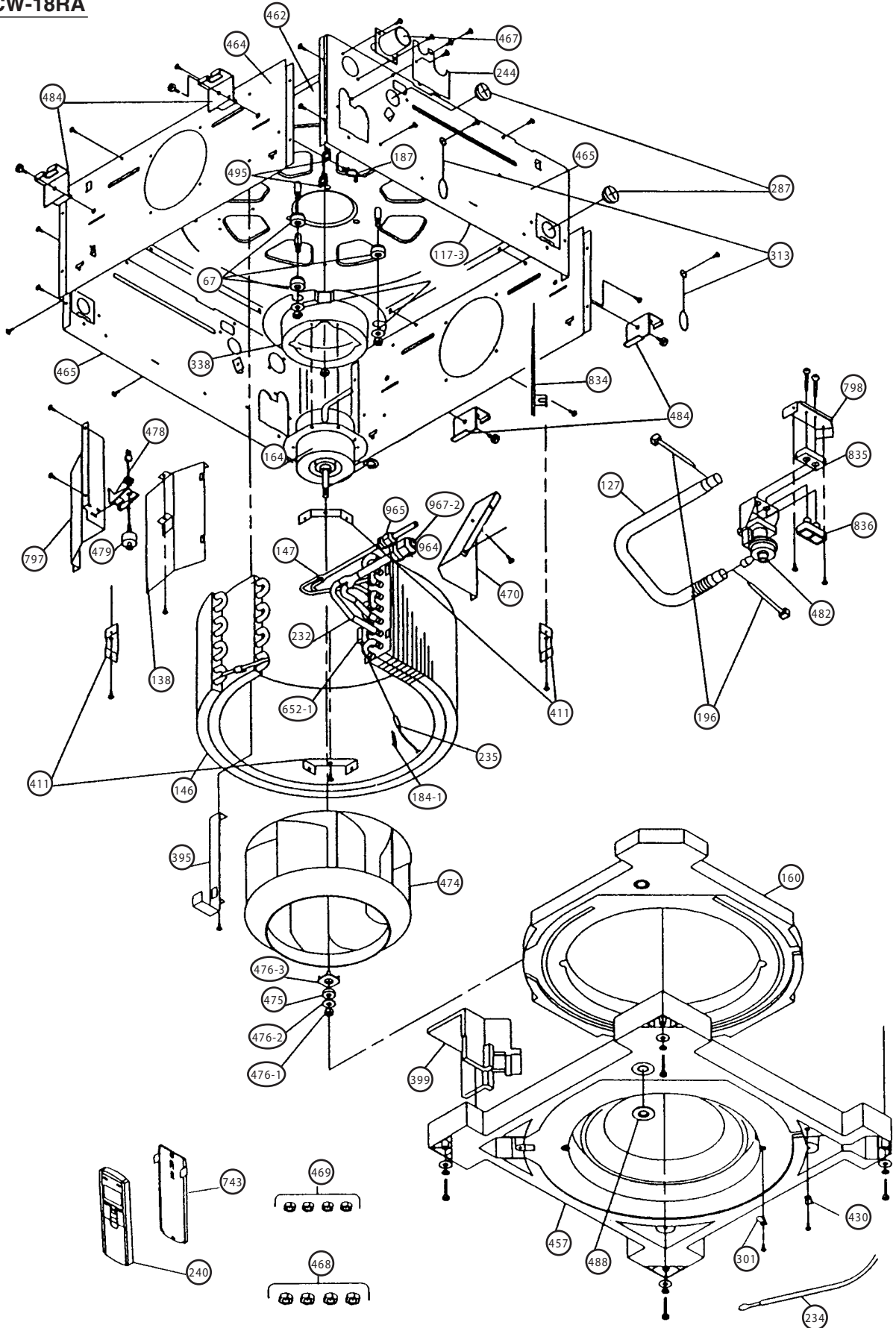

Models : RCW-12
RCW- 12R
RCW-14
RCW-14R
RCW-18A
RCW-18RA

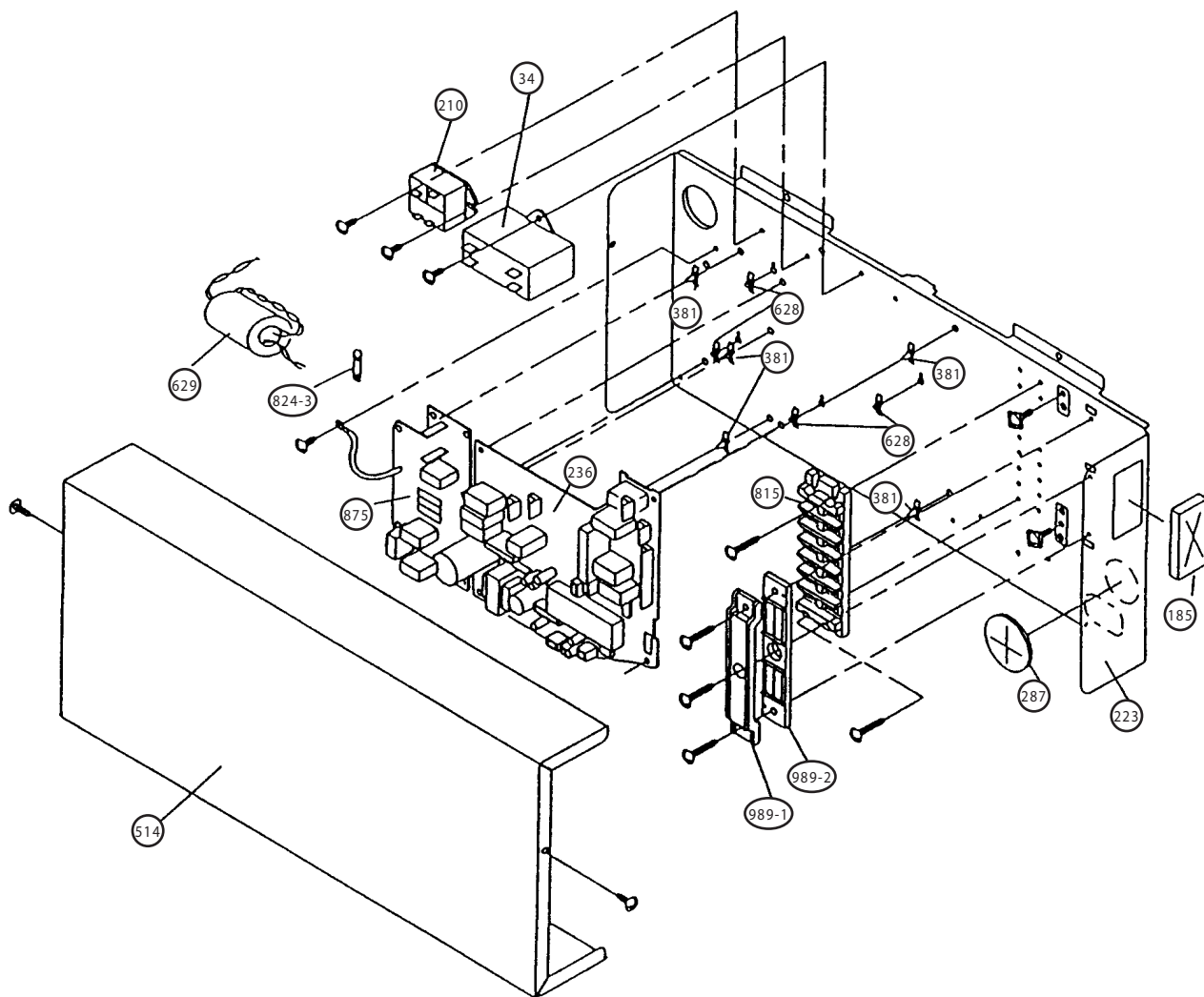

Model : CGC-8

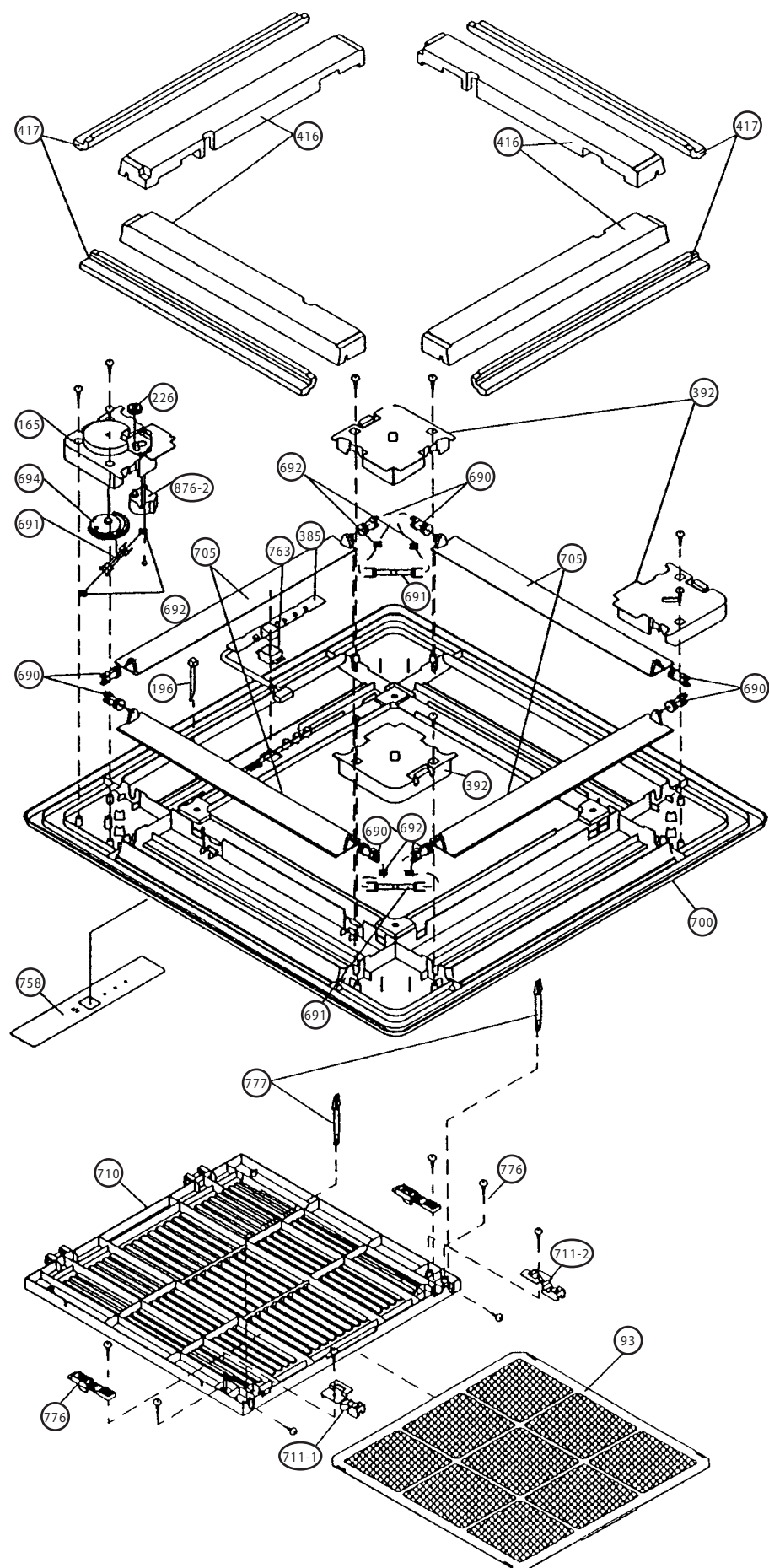

Models : RO-12CA
RO-12HA
RO-14CA
RO-14HA
RO-18CA
RO-18HA

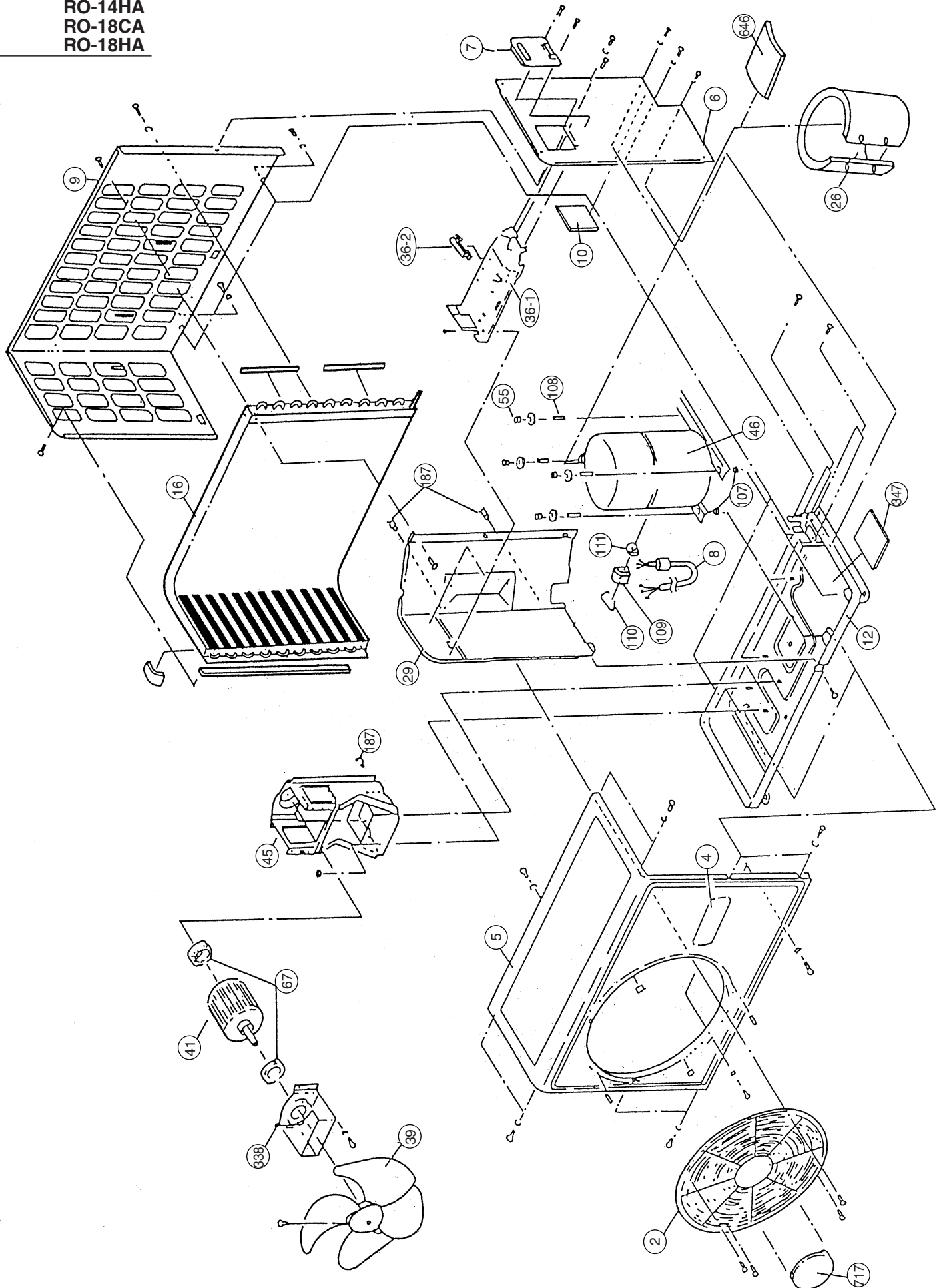

Models : RO-12CA
RO-14CA

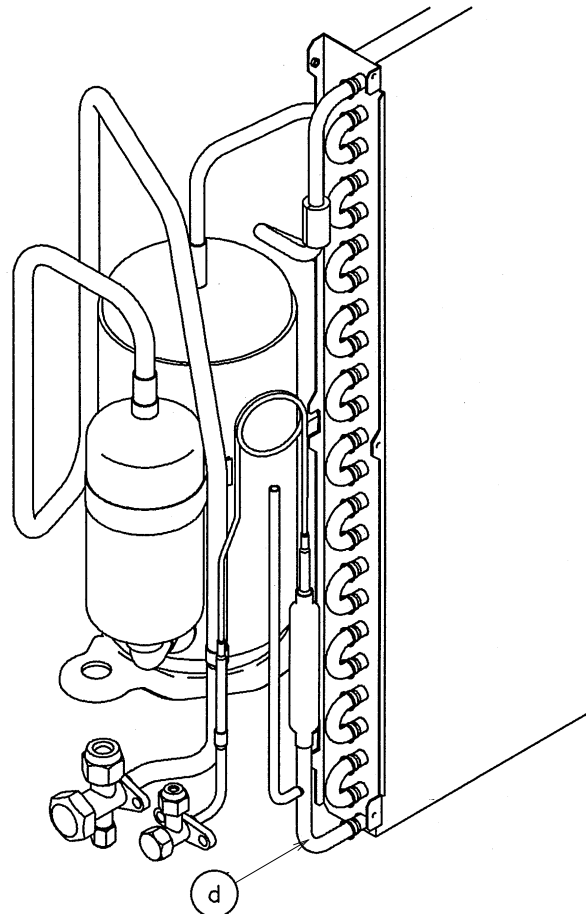
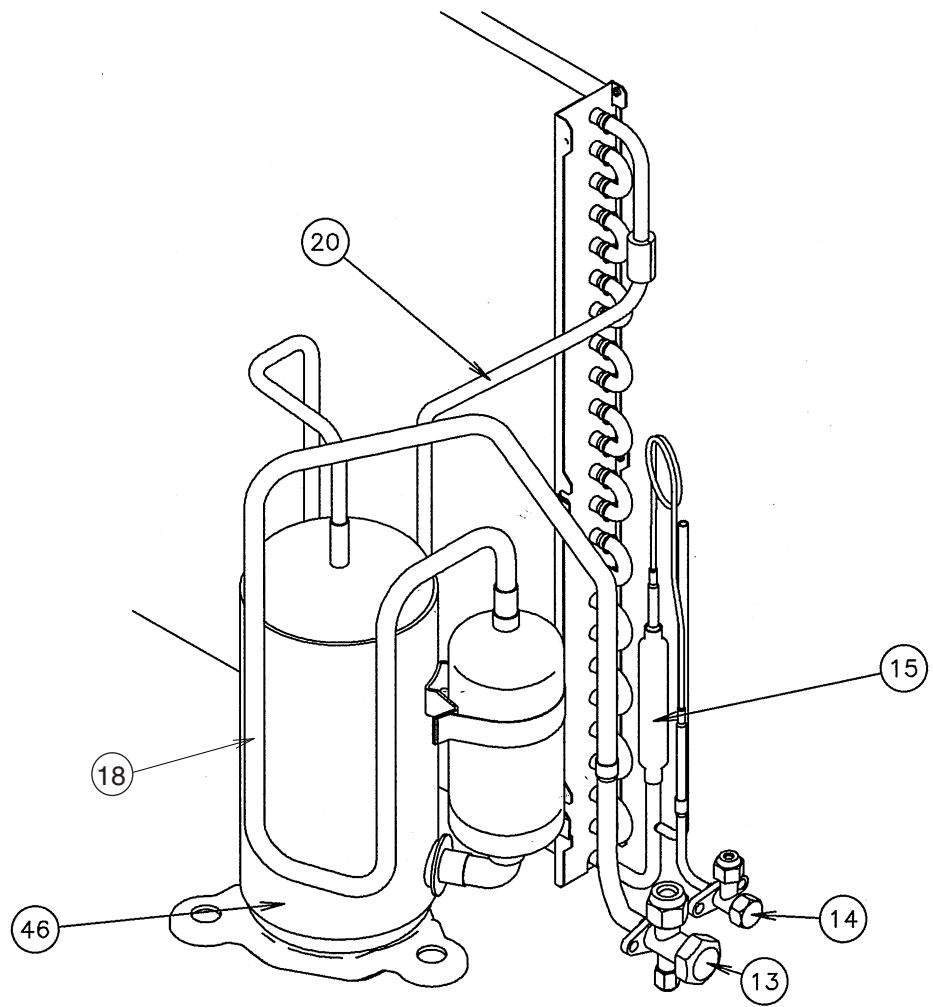

Models : RO-12HA
RO-14HA

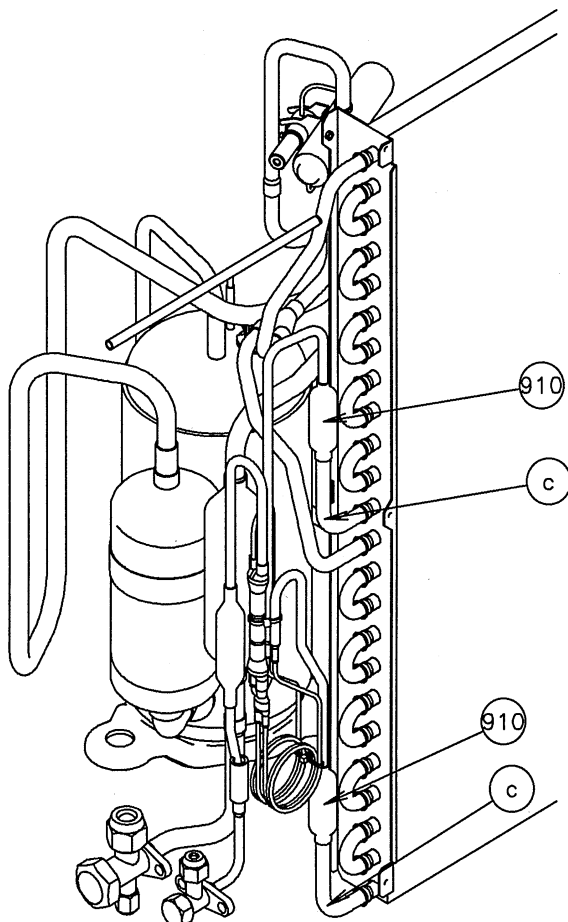
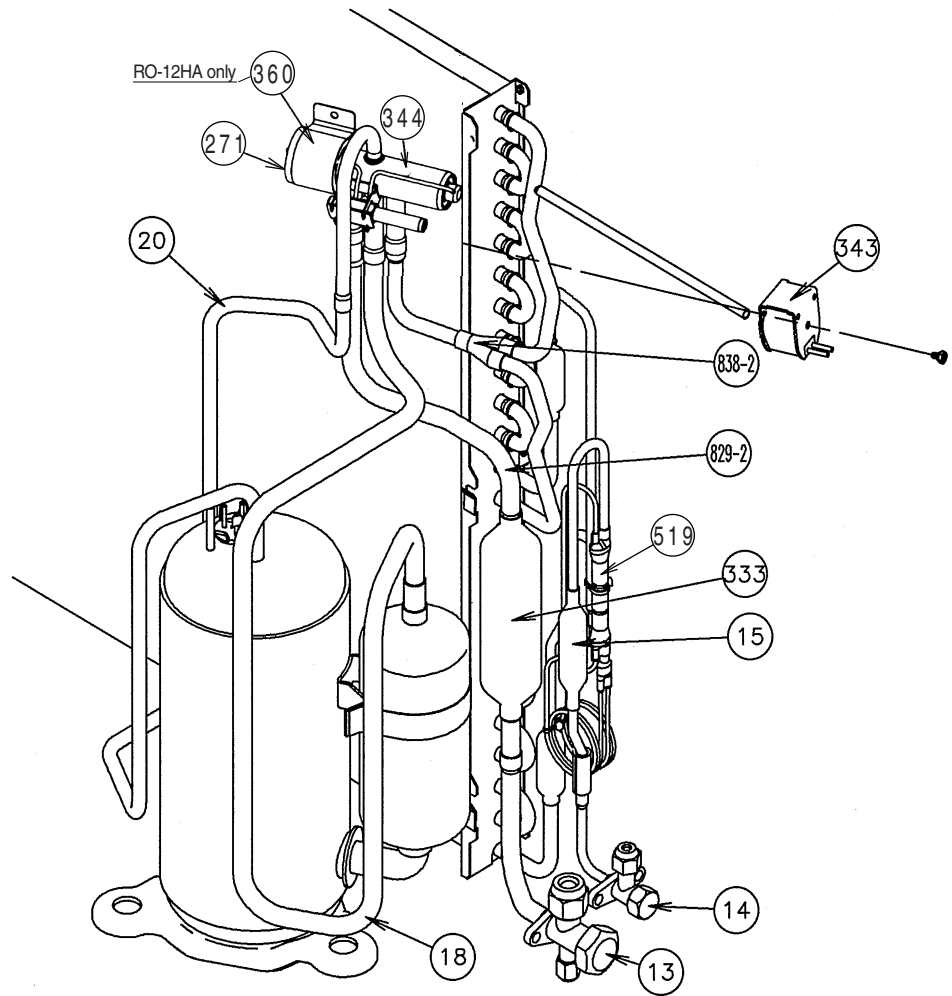

Model : RO-18CA

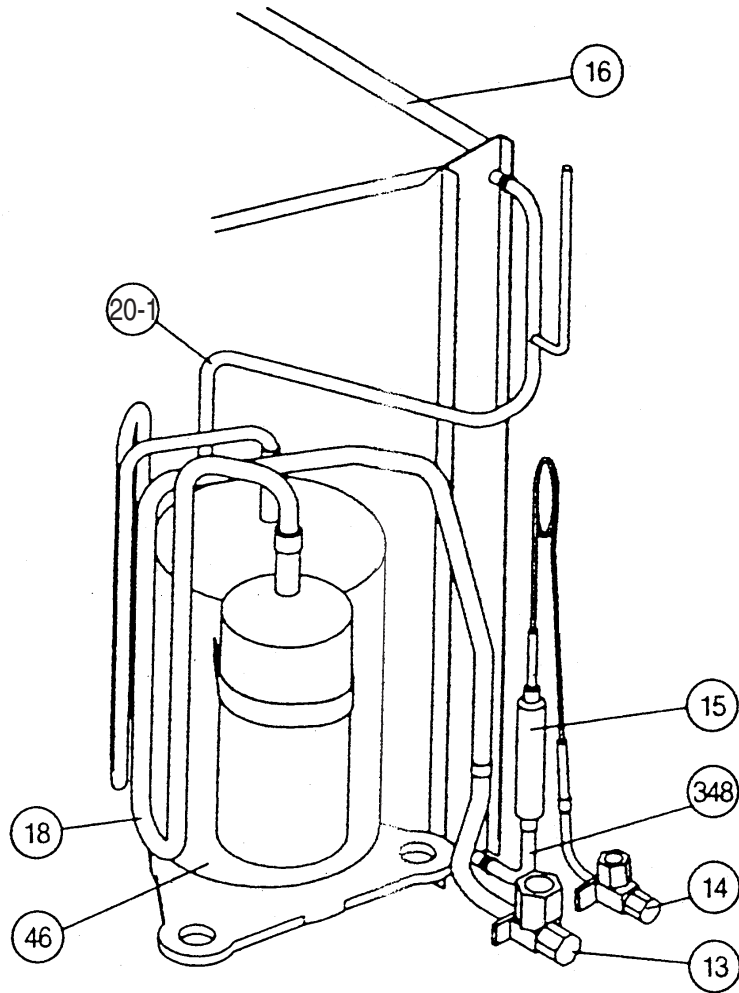

Model : RO-18HA

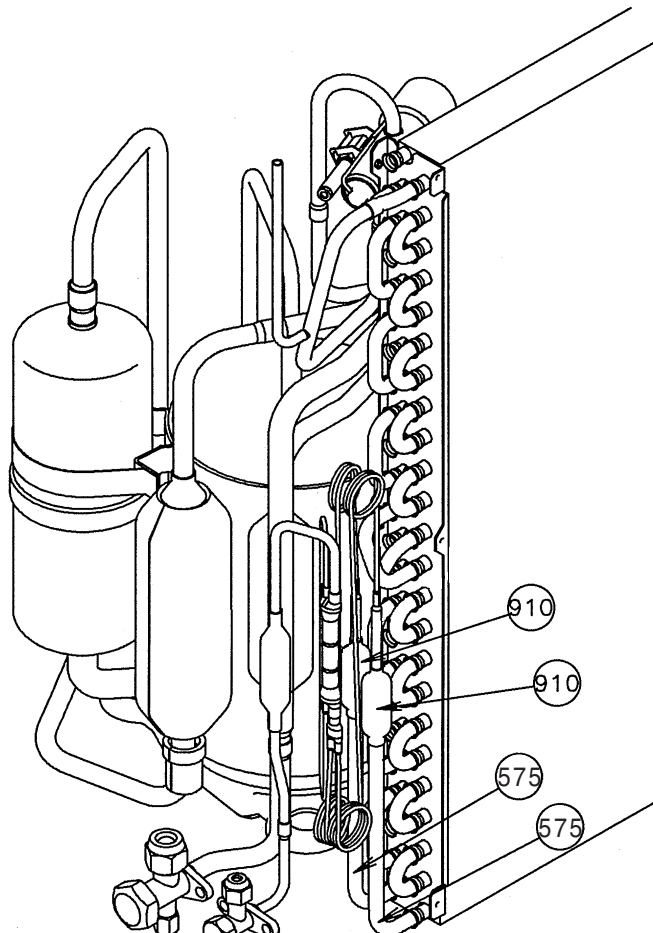
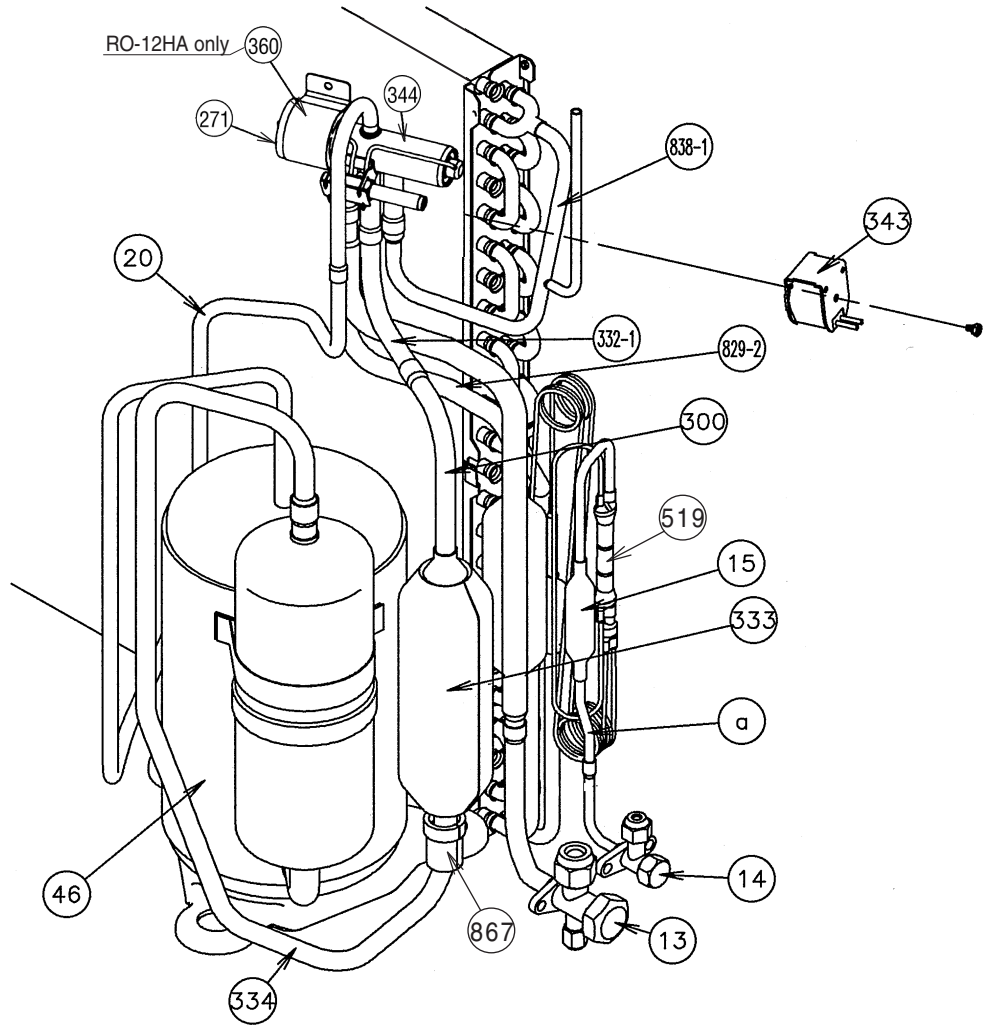

Models: RO-12CA
RO-12HA
RO-14CA
RO-14HA
RO-18CA
RO-18HA

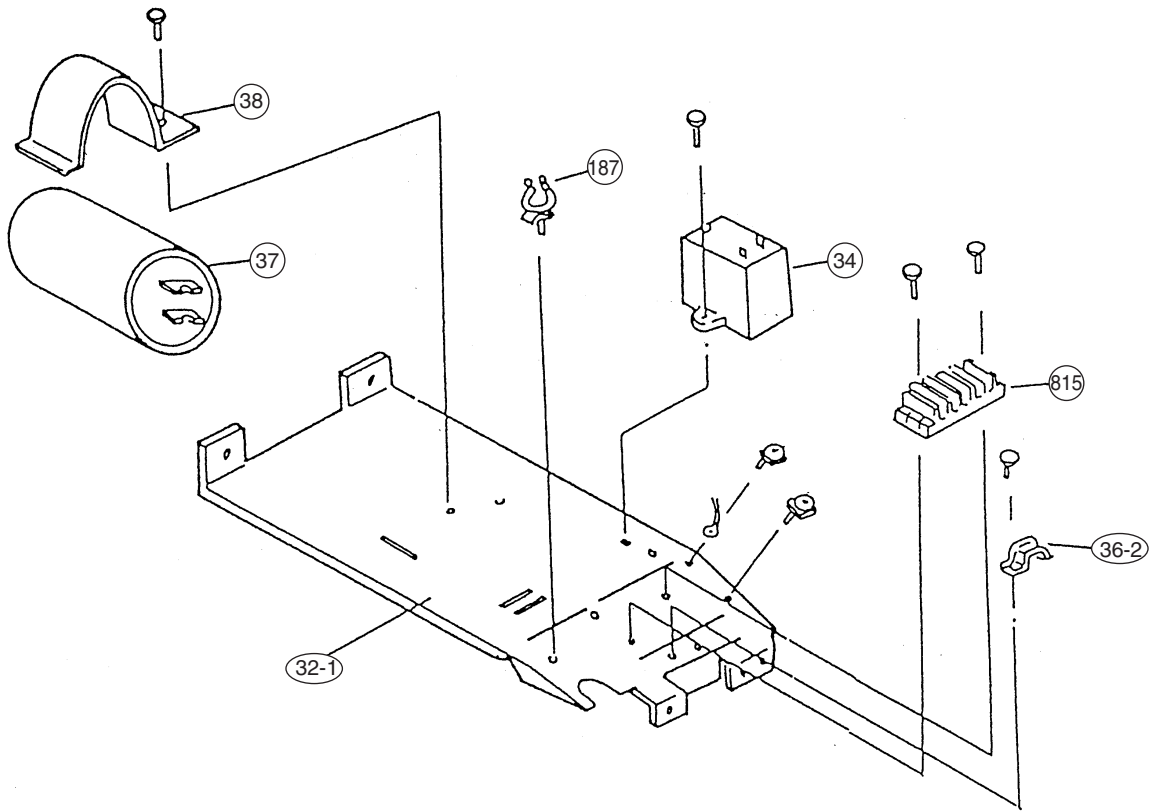

PARTS LIST

INDOOR UNIT

Ref. No.	Description	Prat No.						Order Qty
		RCW-12	RCW-12R	RCW-14	RCW-14R	RCW-18A	RCW-18RA	
34	Capacitor (Fan Motor)	9704305046	9704305046	9704305046	9704305046	9704305046	9704305046	
67	Rubber	9361279001	9361279001	9361279001	9361279001	9361279001	9361279001	
117-3	Special Washer M6	313306391007	313306391007	313306391007	313306391007	313306391007	313306391007	
127	Drain Hose	9359659013	9359659013	9359659013	9359659013	9359659013	9359659013	
138	Separate Wall-A	9359647003	9359647003	9359647003	9359647003	9359647003	9359647003	
146	Evaporator Assy	9360009012	9360009012	9360009012	9360009012	9360009012	9360009012	
147	Inlet pipe (Eva.) Assy	9360010018	9360010018	9360010018	9360010018	9360010018	9360010018	
160	Drain Pan	9359651000	9359651000	9359651000	9359651000	9359651000	9359651000	
164	Fan Motor Assy-IN	9601040019	9601040019	9601040019	9601040019	9601040019	9601040019	
184-1	Thermo. Spring-A	313728262708	313728262708	313728262708	313728262708	313728262708	313728262708	
185	Rubber Bushing	313005066051	313005066051	313005066051	313005066051	313005066051	313005066051	
187	Clamp No.1219	313361271706	313361271706	313361271706	313361271706	313361271706	313361271706	
196	Clamp SKB-150	313035356905	313035356905	313035356905	313035356905	313035356905	313035356905	
210	Main Relay	9356781007	9356781007	9356781007	9356781007	9356781007	9356781007	
223	Control Box	9359661016	9359661016	9359661016	9359661016	9359661016	9359661016	
232	Outlet Pipe (Eva.) Assy	9360011015	9360011015	9360011015	9360011015	9360011015	9360011015	
234	Thermistor Assy	9703299032	9703299032	9703299032	9703299032	9703299032	9703299032	
235	Thermistor Assy	9703297014	9703297014	9703297014	9703297014	9703297014	9703297014	
236	Controller PCB Assy	9701941155	9701941131	9701941155	9701941131	9701941155	9701941193	
240	Remote Control Unit	9359913085	9359913078	9359913085	9359913078	9359913085	9359913078	
244	Pipe Cover	9359646006	9359646006	9359646006	9359646006	9359646006	9359646006	
287	Cap (Power)	9352173011	9352173011	9352173011	9352173011	9352173011	9352173011	
301	Clamp NK-2N	313985355201	313985355201	313985355201	313985355201	313985355201	313985355201	
313	Hooking Wire	9359983002	9359983002	9359983002	9359983002	9359983002	9359983002	
338	Motor Fixture	9359656005	9359656005	9359656005	9359656005	9359656005	9359656005	
381	Locking Spacer	313209391506	313209391506	313209391506	313209391506	313209391506	313209391506	
395	Supporter (Eva.)	9359669005	9359669005	9359669005	9359669005	9359669005	9359669005	
399	Air Duct	9359660002	9359660002	9359660002	9359660002	9359660002	9359660002	
411	Supporter-A	9359655008	9359655008	9359655008	9359655008	9359655008	9359655008	
430	Clamp NK-7N	313095365602	313095365602	313095365602	313095365602	313095365602	313095365602	
457	Drain Pan Support	9359652007	9359652007	9359652007	9359652007	9359652007	9359652007	
462	Top Cover Plate	9359642015	9359642015	9359642015	9359642015	9359642015	9359642015	
464	Body-A	9359643005	9359643005	9359643005	9359643005	9359643005	9359643005	
465	Body-B	9359645009	9359645009	9359645009	9359645009	9359645009	9359645009	
467	Drain Port	313005415658	313005415658	313005415658	313005415658	313005415658	313005415658	
468	Special Nut-A (Large)	313005446653	313005446653	313005446653	313005446653	313005446653	313005446653	
469	Special Nut-B (Small)	313005446759	313005446759	313005446759	313005446759	313005446759	313005446759	
470	Separate Wall-B	9359648000	9359648000	9359648000	9359648000	9359648000	9359648000	
474	Turbo Fan	9359658009	9359658009	9359658009	9359658009	9359658009	9359658009	
475	Turbo Fan Rubber	9366013006	9366013006	9366013006	9366013006	9366013006	9366013006	
476-1	Special Nut M8	313005360755	313005360755	313005360755	313005360755	313005360755	313005360755	
476-2	Special Washer	301801185049	301801185049	301801185049	301801185049	301801185049	301801185049	
476-3	Special Washer	9359954002	9359954002	9359954002	9359954002	9359954002	9359954002	
478	Sensor M. Bracket	9359654001	9359654001	9359654001	9359654001	9359654001	9359654001	
479	Float Switch	313005416154	313005416154	313005416154	313005416154	313005416154	313005416154	
482	Pump Unit	9359974000	9359974000	9359974000	9359974000	9359974000	9359974000	
484	Hanger Metal	9359644002	9359644002	9359644002	9359644002	9359644002	9359644002	
488	Drain Pan Plug	9359653004	9359653004	9359653004	9359653004	9359653004	9359653004	
495	Clamp No.2U46	9352715006	9352715006	9352715006	9352715006	9352715006	9352715006	
514	Control Box Cover	9359662006	9359662006	9359662006	9359662006	9359662006	9359662006	
628	Locking Spacer-B	313005446558	313005446558	313005446558	313005446558	313005446558	313005446558	
629	EMI Filter	0400197119	0400197119	0400197119	0400197119	0400197119	0400197119	
652-1	Therm. Holder Pipe	313806262805	313806262805	313806262805	313806262805	313806262805	313806262805	
743	Remote Control Unit Holder Case	9359955016	9359955016	9359955016	9359955016	9359955016	9359955016	
797	Separate Wall-C	9359649007	9359649007	9359649007	9359649007	9359649007	9359649007	
798	Pump Hook Bracket	9359650003	9359650003	9359650003	9359650003	9359650003	9359650003	
815	Terminal-7P	9358660102	9358660102	9358660102	9358660102	9358660102	9358660102	
824-3	Fuse	0600222512	0600222512	0600222512	0600222512	0600222512	0600222512	
834	Wire Cover	9359878001	9359878001	9359878001	9359878001	9359878001	9359878001	
835	Cushion-A (For Pump)	9352211003	9352211003	9352211003	9352211003	9352211003	9352211003	
836	Cushion-B (For Pump)	9356084016	9356084016	9356084016	9356084016	9356084016	9356084016	
875	Filter PCB Assy	9702326012	9702326012	9702326012	9702326012	9702326012	9702326012	
964	Flare Nut-A	313996239804	313996239804	313996239804	313996239804	313996239804	313996239804	
965	Flare Nut-B	9351062019	9351062019	9351062019	9351062019	9351062019	9351062019	
967-2	Bonnet-B	9301858006	9301858006	9301858006	9301858006	9301858006	9301858006	
989-1	Cord Clamp-A	9359822011	9359822011	9359822011	9359822011	9359822011	9359822011	
989-2	Cord Clamp-B	9359823018	9359823018	9359823018	9359823018	9359823018	9359823018	







OUTDOOR UNIT

Ref. No.	Description	Prat No.						Order Q'ty
		RO-12CA	RO-12HA	RO-14CA	RO-14HA	RO-18CA	RO-18HA	
2	Fan Cover	9350214020	9350214020	9350214020	9350214020	9350214020	9350214020	
4	Emblem-Rear "FUJI ELECTRIC"	9361328006	9361328006	9361328006	9361328006	9361328006	9361328006	
5	Cabinet-A, Painted	9303876015	9303876015	9303876015	9303876015	9303876015	9303876015	
6	Cabinet-C, Painted	9353549013	9353549013	9353549013	9353549013	9353549013	9353549013	
7	Connector Cover	9358011010	9358011010	9358011010	9358011010	9358011010	9358011010	
8	Wire Assy (Shield)-D	-----	-----	9350215010	9350215010	9370945027	9370945027	
9	Cabinet-B, Painted	9303874011	9303874011	9303874011	9303874011	9303874011	9303874011	
10	Noise Insulation-E	313791106305	313791106305	313791106305	313791106305	313791106305	313791106305	
12	Base Assy	9353452054	9353452054	9353452054	9353452054	9353452054	9353452054	
13	3-Way Valve Assy	9364524009	9364524009	9364524009	9364524009	9364524009	9364524009	
14	2-Way Valve Assy	9358023013	9358023013	9358023013	9358023013	9358023013	9358023013	
15	Dryer	9368111014	9368112011	9368111014	9368112011	9368111014	9368112011	
16	Condenser Assy	9353455055	9360672018	9353455055	9360672018	9353455055	9353455048	
17	U-Pipe (Y)	-----	-----	-----	-----	-----	313728127102	
18	Suction Pipe	9371297026	9371297019	9371297026	9371297019	-----	-----	
20	Discharge Pipe	9371298023	9371298016	9371298023	9371298016	-----	9369562006	
20-1	Discharge Pipe Assy	-----	-----	-----	-----	9368182007	-----	
21	Discharge Pipe-B	-----	9358634004	-----	9358634004	-----	9358634004	
26	Compressor Cover	9370184006	9370184006	9370184006	9370184006	9363020007	9363020007	
29	Separate Wall	313986033213	313986033213	313986033213	313986033213	313986033213	313986033213	
32-1	Control Box Metal-A	9365672013	9365672013	9365672013	9365672013	9365672013	9365672013	
34	Capacitor (Fan Motor)	9357965024	9357965024	9357965024	9357965024	9357965024	9357965024	
36-2	Cord Holder Metal	9356362008	9356362008	9356362008	9356362008	9356362008	9356362008	
37	Running Capacitor	9357211084	9357211084	9356386035	9356386035	9704436023	9704436023	
38	Capacitor Clamp	313468061808	313468061808	313468061808	313468061808	9351770013	9351770013	
39	Propeller Fan Assy	9300855013	9300855013	9300855013	9300855013	9300855013	9300855013	
41	Fan Motor Assy-Outer	9600738061	9600738061	9600738061	9600738061	9600738047	9600738047	
45	Motor Fixing Table Assy	313029311100	313029311100	313029311100	313029311100	313029311100	313029311100	
46	Compressor Assy	9365866009	9365866009	9364723006	9364723006	9368175009	9368175009	
55	Special Nut M8 (For Comp.)	9355091008	9355091008	9355091008	9355091008	9355091008	9355091008	
67	Rubber	313659068604	313659068604	313659068604	313659068604	313659068604	313659068604	
107	Rubber Seat-A (For Comp.)	9359425014	9359425014	9359425014	9359425014	9351049010	9351049010	
108	Sleeve-A (For Comp.)	313093081706	313093081706	313093081706	313093081706	313093081706	313093081706	
109	Terminal Cover (For Comp.)	9363263008	9363263008	9364724003	9364724003	9351048013	9351048013	
110	Lock Wire	313202059706	313202059706	313202059706	313202059706	313202059706	313202059706	
111	Terminal Packing	313202059807	313202059807	313202059807	313202059807	313202059807	313202059807	
187	Clamp No.1219	313361271706	313361271706	313361271706	313361271706	313361271706	313361271706	
271	4-Way Valve Rubber	-----	313728251908	-----	313728251908	-----	313728251908	
300	Suction Pipe-C	-----	-----	-----	-----	-----	9371276021	
332-1	Suction Pipe-D	-----	-----	-----	-----	-----	9367135004	
333	Accumulator	-----	9303037003	-----	9303037003	-----	9350363018	
334	Suction Pipe-B	-----	-----	-----	-----	-----	9371275031	
338	Motor Fixture	313029297108	313029297108	313029297108	313029297108	313029297108	313029297108	
343	Solenoid Coil	-----	9704061010	-----	9704061010	-----	9359616092	
344	4-Way Valve	-----	9307556012	-----	9307556012	-----	313943302804	
347	Noise Insulation-D	313712304109	313712304109	313712304109	313712304109	313712304109	313712304109	
348	Outlet Pipe	-----	-----	-----	-----	9363433005	-----	
348-1	Outlet Pipe B	-----	-----	-----	-----	-----	9365391020	
360	4-Way Valve Band	-----	313986251802	-----	-----	-----	313986251802	
519	Check Valve Assy	-----	9360680006	-----	9360688002	-----	9361076006	
575	Condensing Pipe-C	-----	-----	-----	-----	-----	9361069008	
646	Compressor Cover-B	313986355101	313986355101	313986355101	313986355101	9363021004	9363021004	
717	Center Plate	9351253011	9351253011	9351253011	9351253011	9351253011	9351253011	
815	Terminal-5P	9356497021	9356497021	9356497021	9356497021	9356497021	9356497021	
829-2	Joint Pipe (VALVE)	-----	9371296012	-----	9371296012	936344002	9371296012	
838-1	Inlet Pipe A Assy	-----	-----	-----	-----	-----	9366859017	
829-2	Joint Pipe (VALVE)	-----	9371296012	-----	9371296012	936343002	9371296012	
838-2	Inlet Pipe Assy	-----	9366859017	-----	9366859017	-----	-----	
910	Strainer B	-----	9365099018	-----	9365099018	-----	9365099018	
a	Joint Pipe (Dryer)	-----	-----	-----	-----	-----	9371295015	
c	Condensing Pipe	-----	9360679000	-----	9360679000	-----	-----	
d	Condensing Assy	9371378015	-----	9371378015	-----	-----	-----	



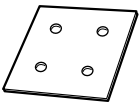
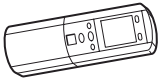

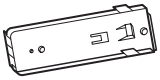
GRILLE ASSY (CGC-8)

Ref. No.	Description	Part No.	Ord. Q'ty	Ref. No.	Description	Part No.	Ord. Q'ty
93	Filter	9359632009		694	Cam Gear	9359628002	
165	Motor Cover	9359623014		700	Panel	9359619017	
196	Clamp SKB-150	313035356905		705	Louver	9359624011	
226	Motor Gear	9359629009		710	Intake Grille	9360543011	
385	Indicator PCB Assy	9702224011		711-1	Filter Clamp-A	9359634003	
392	Cover-A	9359622017		711-2	Filter Clamp-B	9359635000	
416	Insulation (Panel)-A	9359620006		758	Decoration Plate	9360862013	
417	Insulation (Panel)-B	9359621003		763	Receiver Cover	9359630005	
690	Joint-A	9359626008		776	Grille Stopper	9359633013	
691	Joint-B	9359627005		777	Grille Hook	9359761006	
692	Joint Shaft	9359625001		876-2	Step Motor-V	9360307019	





INDOOR UNIT ACCESSORIES

Name and Shape	Application	RCW-12 RCW-14 RCW-18A	RCW-12R RCW-14R RCW-18RA
Coupler heat insulator 	For indoor side pipe joint	9350716029	9350716029
		9352766015	9352766015
Special nut A (large flange) 	For installing indoor unit	313005446653	313005446653
Special nut B (small flange) 	For installing indoor unit	313005446759	313005446759
Template 	For ceiling hole cutting	9360256003	9360256003
Remote control unit 	Use for air conditioner operation	9359913085	9359913078
Battery (pen light) 	For remote control unit	0600185534	0600185534
Remote control unit holder 	For mounting the remote control unit	9359955016	9359955016
Tapping screw ($\phi 3 \times 12$) 	For remote control unit holder installation	301141533125	301141533125

OUTDOOR UNIT ACCESSORIES

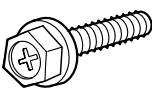
Name and Shape	Application	RO-12CA RO-14CA RO-18CA	RO-12HA RO-14HA RO-18HA
Hexagon Wrench 	For air purge	9351228019	9351228019
Pipe (drain) 	For outdoor unit drain piping work (Heat & Cool model only))	----	313728031005
Flexible tube 		----	313013042915
Cap (drain) 		----	313166024302

GRILLE ASSY ACCESSORIES

Name and Shape	Application	Part No
Bolt 	For opening the refrigerant valve on the outdoor unit	9360120021
Washer 	For mounting grille	301801155020
Spring washer 	For mounting grille	301821150218
Blower cover insulation 	For discharged air	9360047007



MANUFACTURER :

Fuji Denki Sosetsu Co., Ltd.

Tokyo, Japan

0304G2223



Большая библиотека технической документации

<https://splitsystema48.ru/instrukcii-po-ekspluatacii-kondicionerov.html>

каталоги, инструкции, сервисные мануалы, схемы.